

X Range Refrigerant Gas Detector



Key Features:

- 24VAC or DC Power Input
- Traffic Light Indicator Display Changes Color Dependent On Gas Levels
- Modern & Compact Design
- Plug & Play Installation
- Standalone Detector or Used With An S&S Middle East Controller
- Modbus Communications
- Alarm Relay Dry Contact
- In-Built Audible Alarm

Product Overview:

The TFT range of S&S Middle East detectors work in combination with the S&S Middle East range of Gas Detection panels. The S&S Refrigerant X range features an NDIR sensor for industrial and commercial indoor applications. Compact, modern, digital design makes the units aesthetically pleasing and easy to install.

Detectable Gases Available:

GAS

GAS	Model#	Pre Alarm (PPM)	High Alarm (PPM)	Mounting Height
R-1233zd	RTFT-PRO-1233ZD	75	1000	1ft A.F.F.
R-1234yf	RTFT-LITE-1234YF	175	1000	1ft A.F.F.
R-1234ze	RTFT-LITE-1234ZE	175	1000	1ft A.F.F.
R-123	RTFT-PRO-123		50	1ft A.F.F.
R-125	RTFT-PRO-125	75	1000	1ft A.F.F.
R-134a	RTFT-LITE-134A	175	1000	1ft A.F.F.
R-143a	RTFT-PRO-143A	75	1000	1ft A.F.F.
R-227ea	RTFT-PRO-227EA	75	1000	1ft A.F.F.
R-22	RTFT-PRO-22	75	1000	1ft A.F.F.
R-32	RTFT-LITE-32	350	1000	1ft A.F.F.
R-404a	RTFT-LITE-404A	175	1000	1ft A.F.F.
R-407a	RTFT-PRO-407A	75	1000	1ft A.F.F.
R-407c	RTFT-LITE-407C	175	1000	1ft A.F.F.
R-407f	RTFT-PRO-407F	75	1000	1ft A.F.F.
R-410a	RTFT-LITE-410A	350	1000	1ft A.F.F.
R-417a	RTFT-PRO-417A	75	1000	1ft A.F.F.
R-422a	RTFT-PRO-422A	75	1000	1ft A.F.F.
R-422d	RTFT-PRO-422D	75	1000	1ft A.F.F.
R-424a	RTFT-PRO-424A	75	990	1ft A.F.F.

GAS	Model#	Pre Alarm (PPM)	High Alarm (PPM)	Mounting Height
R-427a	RTFT-PRO-427A	75	1000	1ft A.F.F.
R-434a	RTFT-PRO-434A	75	1000	1ft A.F.F.
R-438a	RTFT-PRO-438A	75	990	1ft A.F.F.
R-442a	RTFT-PRO-442A	75	1000	1ft A.F.F.
R-448a	RTFT-PRO-448A	75	860	1ft A.F.F.
R-449a	RTFT-LITE-449A	175	800	1ft A.F.F.
R-450a	RTFT-PRO-450A	75	880	1ft A.F.F.
R-452a	RTFT-PRO-452A	75	790	1ft A.F.F.
R-452b	RTFT-PRO-452B	75	870	1ft A.F.F.
R-453a	RTFT-PRO-453B	75	1000	1ft A.F.F.
R-454a	RTFT-PRO-454A	75	690	1ft A.F.F.
R-454b	RTFT-PRO-454B	75	850	1ft A.F.F.
R-454c	RTFT-PRO-454C	75	620	1ft A.F.F.
R-455a	RTFT-PRO-455A	75	650	1ft A.F.F.
R-507	RTFT-PRO-507	75	1000	1ft A.F.F.
R-513a	RTFT-PRO-513A	75	650	1ft A.F.F.
R-514a	RTFT-PRO-514A	75	320	1ft A.F.F.
R-515a	RTFT-PRO-515A	75	810	1ft A.F.F.
R-515b	RTFT-PRO-515B	75	810	1ft A.F.F.

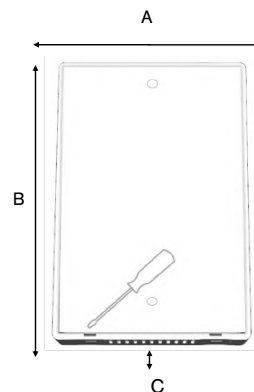
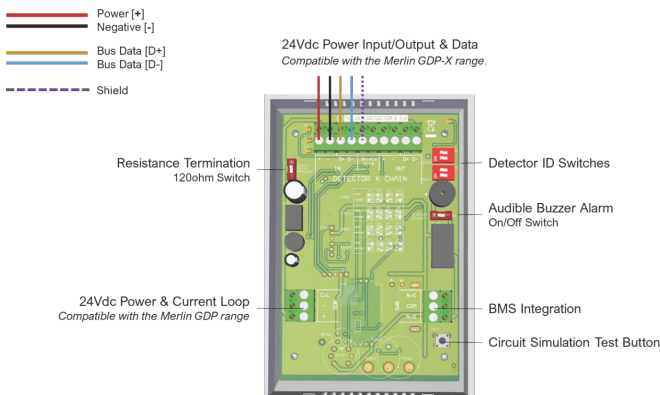

A. 3.74 inch
B. 5.51 inch
C. 1.18 inch



X Range Refrigerant Gas Detector Technical Specifications

General

Model:	Refrigerant X Range
Target Gases:	See table above
Size: (H x W x D)	5.95 x 4.37 x 1.97"
Housing Material:	ABS Polylac - PA765
Mounting:	IFT A.F.F. - Indoor Use - Wall Mounted
Weight	0.3kg

User Interface

Display	1.8" TFT
Screen Brightness:	Non-Adjustable
Visual Indicators:	TFT visual. Green: Normal; Yellow: Pre-Alarm; Red: Alarm
Audible Alarm:	>95dB @ 1m conditions
Buttons:	None
Language:	English

Power Supply

Power Consumption:	90mA Max @ 24 VDC
DC Power:	12-32 VDC - Nominal 24 VDC
Internal Fuse:	None

Equipment

Overvoltage Category:	III
Pollution Degree:	3

I/O

Relay:	Volt Free (Normally Closed / Common / Normally Open) 1x 30vdc 2A (Non-Latching)
--------	---

Environmental

Operating:	-10 ~ 50°C / 14 ~ 122°F 30 ~ 80% RH (non-condensing)
Storage	-25 ~ 50°C / -13~122F° up to 95% RH (non-condensing)
Atmospheric Pressure:	70-110kPa
Altitude Rating:	<2900M

Wiring

Typical	#18-24AWG Power Pair; #18-24AWG Data Pair-Tinned copper.
---------	--

Approvals

Electromagnetic Compatibility and Electrical Safety	BS/IEC/EN 61010-1 EMC EN 50270
---	-----------------------------------

Other

Communication	RS485 MODBUS RTU
---------------	------------------